

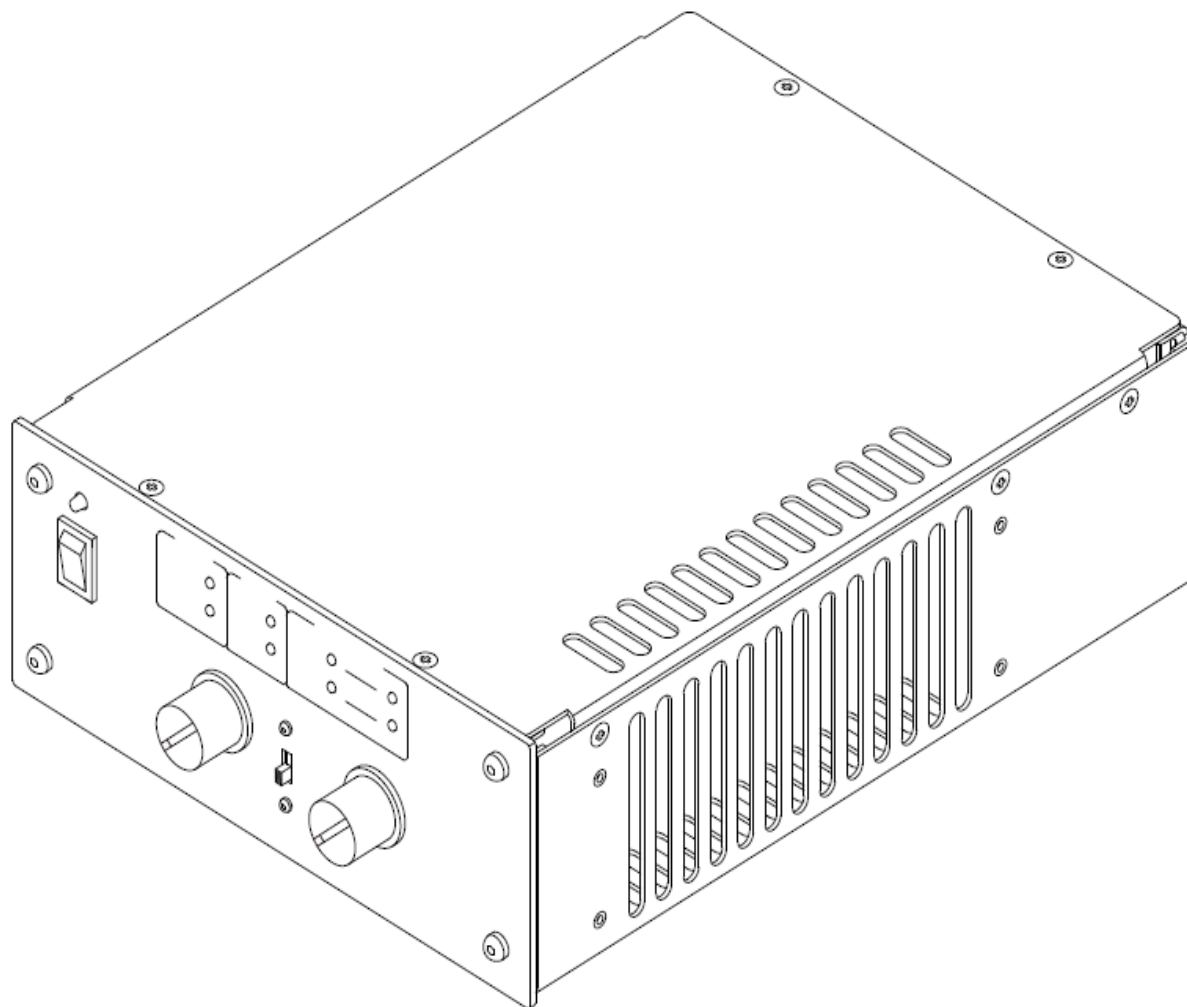

MV-1.11X

Operating Manual



Please Note: All specifications and improvements to and in the design of this unit and this manual are subject to change at any time without any prior written or published noticed.

MV-1.11X Desktop Integrated Amplifier

Thank you for purchasing the MV-1.11X **Desktop Integrated Amplifier**. You will find this amplifier user friendly and virtually indestructible, but it is important that you read through this manual thoroughly before using.

Table of Contents

	Page #
Important Safety Instructions	3
Precautions	4
Introduction	4
Dimensions	5
Front Panel	6
Back Panel	7
Common Operational Features and Protection Schemes	8
Modes	8
Internal Trimming and Adjustments	8
Cooling Requirements	8
Speaker Connections and Installation	9
Troubleshooting	10
Repairs and Servicing	10
Maintenance	10
Amplifier Specifications	11

1. Important Safety Instructions

- 1) Read all Safety Instructions and Documentation before operating the equipment.
- 2) Keep all Safety Instructions.
- 3) Heed all warnings.
- 4) Do not expose the equipment to rain or moisture.
- 5) Keep your equipment in a well ventilated, cooled room or a rack with a rack fan.
- 6) Do not block any ventilation openings.
- 7) Unplug your equipment during lightning storms, or if unused for long periods of time.
- 8) Do not install near any sources that produce heat.
- 9) Do not remove the lid unless qualified to do so.
- 10) Refer servicing of LAR products to qualified service personnel.
- 11) Keep all air vents clean and dust free.
- 12) Make sure power outlets conform to the power requirements.
- 13) Do not change the position of the Mode Switch when the equipment is turned on.
- 14) Protect all wires and cords from being crushed, walked on, or tripped over.
- 15) Do not tamper with your equipment in any way, including any wiring that has been done prior to purchasing.
- 16) Use only with the rack, cart, stand, bracket, or table specified by the manufacturer, or sold with your amplifier. When a cart is used, use caution when moving the cart/apparatus combination to avoid injury from tipping over.





The symbols shown below are internationally accepted symbols that warn of potential hazards with electrical products.



This symbol is used to alert the operator to follow important operating procedures and precautions detailed in documentation.



This symbol is used to warn operators that "dangerous voltages" are present within the equipment enclosure that may pose a risk of electric shock.

	CAUTION RISK OF ELECTRIC SHOCK DO NOT OPEN	
CAUTION: TO REDUCE THE RISK OF ELECTRIC SHOCK, DO NOT REMOVE COVER (OR BACK). NO USER-SERVICEABLE PARTS INSIDE. REFER SERVICING TO QUALIFIED SERVICE PERSONNEL.		



To reduce the risk of fire or electric shock, do not expose this component to water or moisture.

Please ensure that no objects filled with liquids, such as glasses, cups or bottles, opened or closed, are placed on the equipment, or the rack the amplifier is inside of.

To completely disconnect this equipment from the AC mains, disconnect the power supply cord plug from the AC receptacle of the component.

2. Precautions



Your amplifier is protected from internal and external faults, but you should still take the following precautions for optimum performance and safety. Make sure you read through all Precautions, Instructions, and Directions in this manual to avoid any potential damage to your equipment.

Before use, your amplifier must first be configured for proper operation, including input and output wiring hookup. Improper wiring and Mode Selection can result in serious operating difficulties and potential damage to your equipment. Use care when making connections and selecting signal sources. Never change the position of any of the back panel switches with your amplifier on, this could result in potential damage to your amplifier and or anything else wired to it.



Always remember to power down and disconnect all units from mains voltage before making connections. The power cord of equipment should be unplugged from the outlet when left unused for a long period of time. Make sure you hold the power cord plug when removing it from the back of an amplifier. Never pull from the cord, to avoid damage to the plug and or amplifier. Make sure power outlets conform to the power requirements listed on the back of the amplifier. Always make sure your amplifier is turned off before switching any of the back panel switches to change its mode.



Always keep your equipment away from any locations exposed to splashing or spilling liquids. Do not keep in direct sunlight or near anything that produces heat. Keep away from places that accumulate excessive amounts of dust. Do not touch the power plug with wet hands. Doing so is a potential electrical shock hazard.

If your amplifier has been pre-installed and or wired for you, do not make any adjustments unless informed otherwise by your installer or dealer.

Even though your amplifier can handle excessive loads, it is best to not over-drive your amplifier to avoid damage to your hearing. LAR is not responsible for any damage to, or loss of hearing due to excessive use of equipment or over exposure to high volumes.

3. Introduction



For your safety, please thoroughly read through the *“Important Safety Instructions and Precautions”* section of this manual before installing and operating your equipment.

The LAR Audio Systems *MV-1.11X Desktop Integrated Amplifier* is a monaural processed, super low distortion, Class AB audio power amplifier, featuring field configurable operating modes, attributed to a totally unique front end processing architecture.

The MV-1.11X is equipped with non user-defeatable, fast acting opto-coupler based output signal compressors, and anti-thump turn on delay. Our amplifiers utilize linear power supplies, and all signal processing is kept in the analog domain to maximize signal integrity.

This Amplifier also comes with a wide variety of features that include, but are not limited to; amplifier status and activity indication LED's for ease of troubleshooting, internally adjustable gains for all three inputs, and a wide variety of amplifier protection schemes that will be explained throughout this manual.

LAR Audio Systems audio equipment is virtually indestructible, and made to last for decades. To ensure this, we put every piece through extensive quality control inspections, thorough testing and an intense *“Burn-in”* procedure before being delivered. Our goal is to produce systems with high quality sound at an affordable cost.

The MV-1.11X is built to suit a wide variety of customers, and are perfect for a myriad of locations such as offices, bars, restaurants, bowling alleys, fitness centers, yoga studios, funeral homes, and more!

All pieces of equipment come with a no hassle 10 year warranty from documented Date of Purchase to ensure a lifetime of enjoyment from your LAR system, with little to no maintenance.

4. Dimensions

Front View

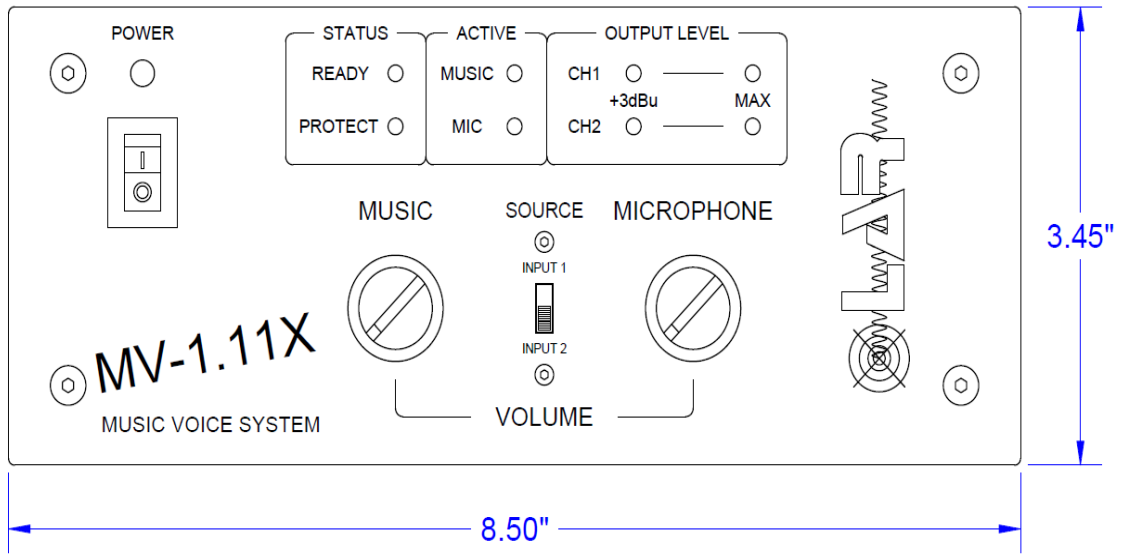

Rear View

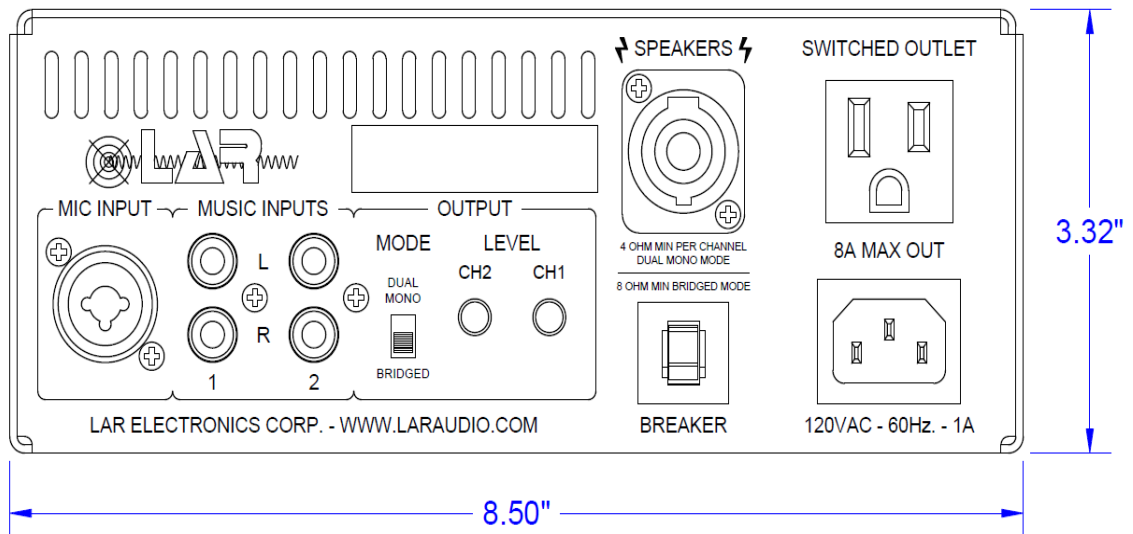

Side View

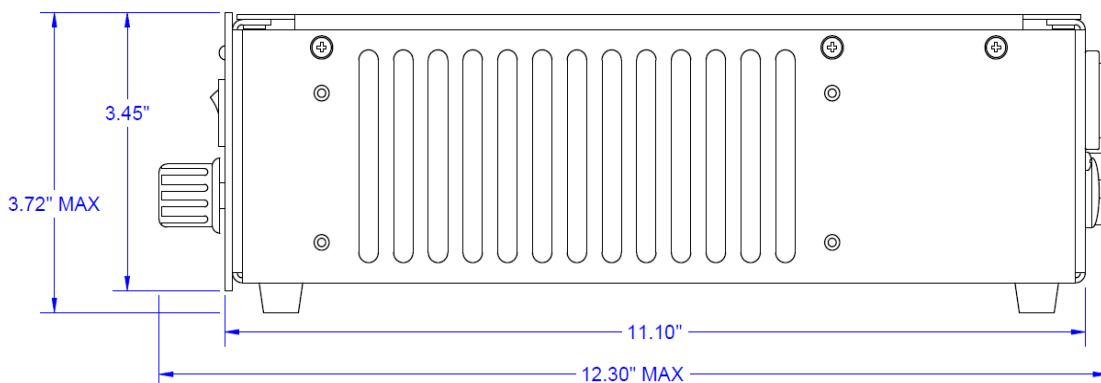

5. Front Panel Layout

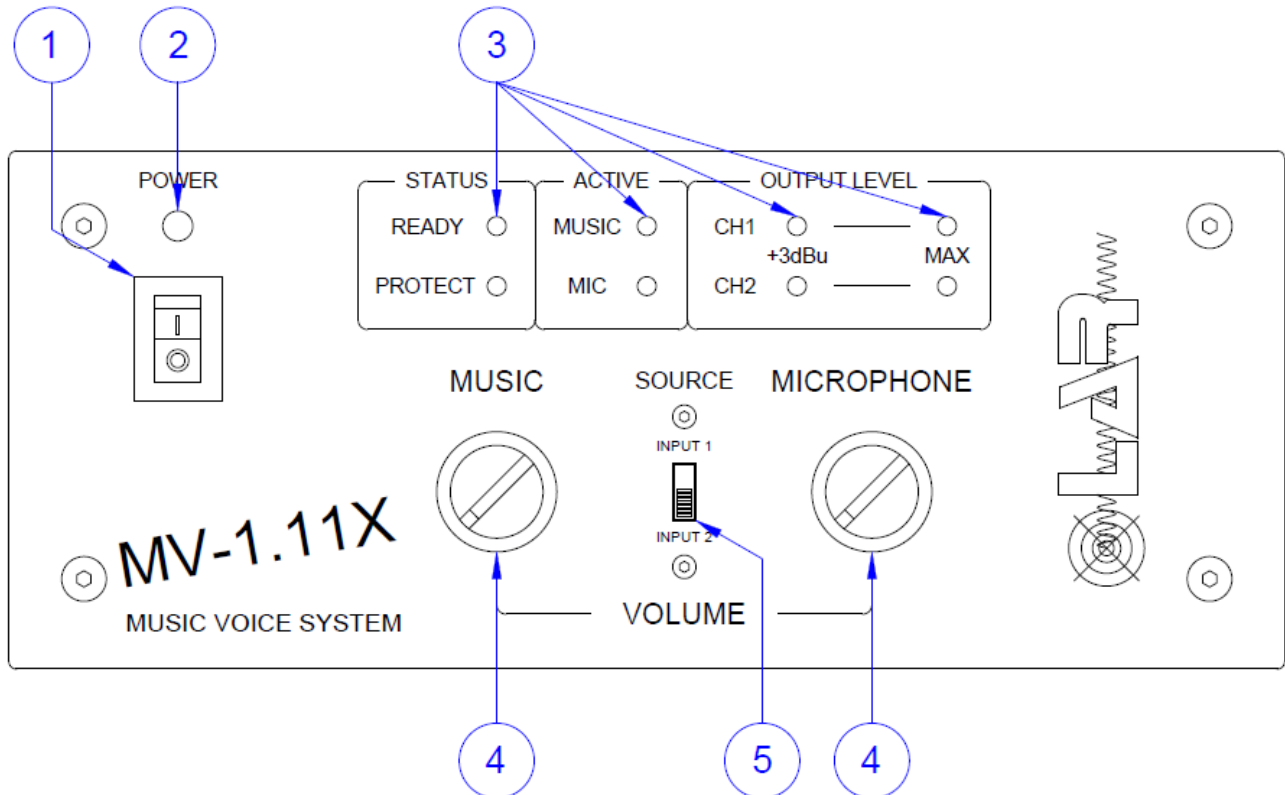

1. Master Power Switch

Rocker Switch – Push up to power unit on.

2. Power Indicator LED

[Green] Power LED Illuminates when the amplifier has been turned on and has AC Mains Power.

3. System Status and Indication LED's

- **Amplifier Status Indicators:** [Green] "READY" and [Red] "PROTECT" illuminate depending on the current state of the unit.

- **Music/Microphone Activity Indicators:** [Blue] indicate whether or not the selected music input jack has program material on it or not. The "MUSIC ACTIVE" LED will begin to flash when a signal of around -18dBu (125mVp) in strength is applied to a rear panel music input jack. In the same fashion, the "MIC ACTIVE" LED will flash when a voice signal greater than about -40dBu (11mVp) is present at of the amplifiers microphone input.

- **Output Level Indicators:** [Yellow and Red] "OUTPUT LEVEL" meters indicates the decibels available to that amplifier channel before the maximum output capability is reached. 3dBu can roughly be interpreted to indicate about 10%, output level respectively. The "MAX" LED's will flash to indicate when the amplifier is operating at max capability.

4. Front Panel Knobs

- **Music Volume Control:** Provides Logarithmically Tapered control of the units selected Music program material.

- **Microphone Volume Control:** Provides Linearly Tapered control of the units Microphone signal.

5. Input Source Selector Switch

1 - of - 2 Style Selector Switch that selects the amplifiers Music Input Source.

6. Back Panel Layout

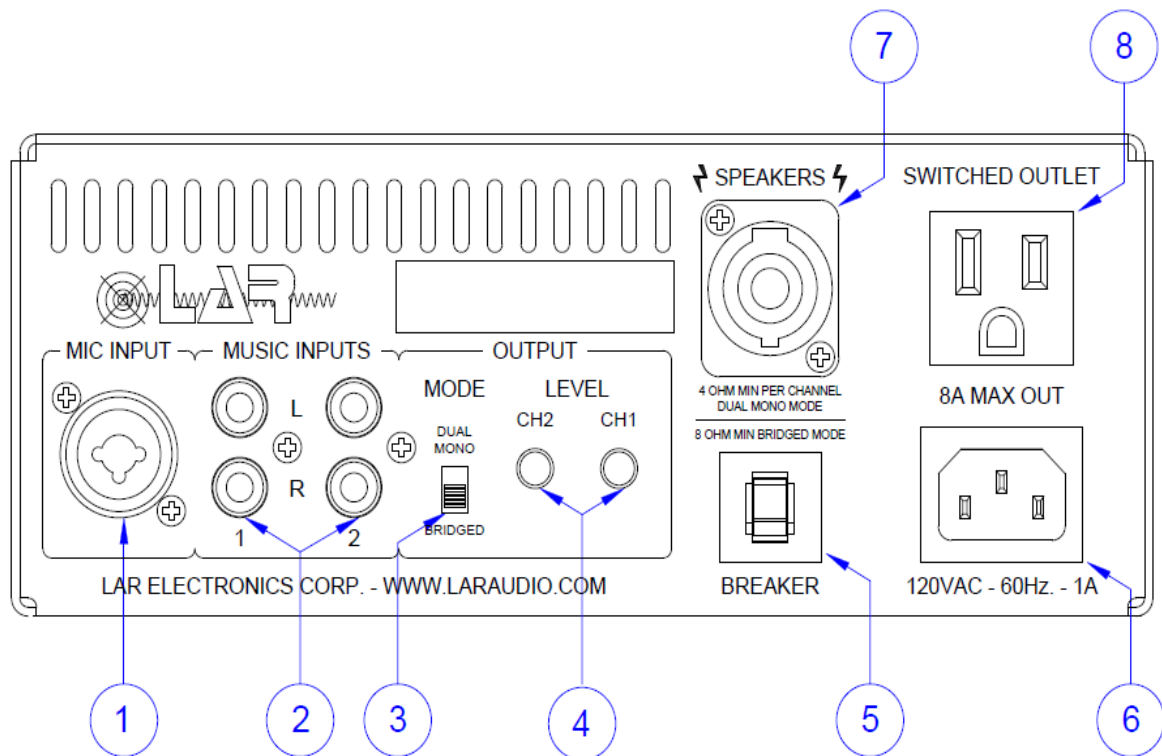

1. Microphone Input

Combo XLR/TRS Jack accepts a Balanced Low - Z Microphone Level signal. It's input impedance is 1k Ω per balanced input leg and has a default +40dB front end gain setting.

2. Music Inputs 1 & 2

Unbalanced Sum Line Level RCA jacks with "1" and "2" under them.

3. Output Mode Selector Switch

1 – of – 2 Style Slide Switch that sets the amplifier to operate in Dual Mono or Bridged Mode.

4. Output Level Adjustment Knobs

Adjusts the Output Gains for each corresponding Channel. These two controls set the amount of gain that the final output stage of the preamplifier has, before the signal is sent to the main power amplifier. They are integrated directly with the output compressor stages and are mainly used to balance the amount of relative gain each channel has to the other.

5. 1A Circuit Breaker

Push-to-Reset style Breaker which protects the Power Supply.

6. AC Mains Inlet

120 VAC - 60Hz Connection for IEC type 60320 power supply cord – 18AWG wiring minimum recommended.

7. Speaker Output

A Neutrik® NL4FX Speakon Connector, or similar compatible part, is used to connect the amplifier to the systems speaker load.

- 4 Ohm Minimum Load Per Channel in Dual Mono mode.
- 8 Ohm Minimum Load in Bridged Mono mode.

8. AC Mains Outlet

Switched Audio Accessory Outlet. 120VAC – 1kW Max Output.

7. Operational Features and Protection Schemes

Output Level Compressors / Limiters: Hardware set, non-defeatable brick wall style opto-coupler based output level compressors are built in, one for each channel. These protect the speakers and transformers connected to the system from being over-driven, causing their cores to become saturated and over heat causing damage.

Power Amplifier Current Limiting: Both amplifier channels output current is always limited to a safe level, regardless of the load placed on the amplifier. Should the speaker load try and draw more power than the design allows for, excess current is wicked away from the outputs drive devices to keep the output transistors within their electrical safe operating limits. Even if the outputs are directly shorted to earth ground, the amplifier will not self-destruct.

Over-Current Shut Down Lockout Protection: If a speakers' load impedance is less than the amplifier is rated for, or a dead short is detected on the speaker terminals for an extended period of time, the equipment will disconnect itself from the speaker load, and the front panel LED's will indicate a fault condition. The amplifier will remain disengaged from the speakers until the unit is powered down for at least 30 seconds. Once the external fault has been cleared, the amplifier can resume normal operation.

DC Output Protection: In the extremely unlikely event that one of the output transistors happen to fail short, or an external DC power source accidentally connects to the amplifiers output lines, the unit will quickly disengage itself from the speaker load, and re-engage automatically once the DC fault is cleared. Should this happen, the front panel "READY" LED [Green] will turn off, and the "PROTECT" LED [Red] will turn on during the fault condition and the unit should be serviced.

AC Mains and Startup Protection: The MV-1.11X amplifier employs a variety of initial turn on protection methods such as a 1A push-to-reset style mains breaker, an Anti-Thump Turn on Delay and Lightning Strike protection via a Metal Oxide Varistor across the switched AC Mains.

8. Modes

DUAL MONO MODE:

This setting lets the full usable spectrum of audio be played through both output channels of the amplifier simultaneously. The unit may operate two separate zones that share the same program material with their overall master volume controlled via the front panel knobs, and their relative volumes set by the corresponding channels "Output Level" adjustment knobs located on the back panel.

BRIDGED MODE:

This setting is primarily used for "70V" distributed speaker systems. Channel 1 passes a full range audio signal, while Channel 2 passes an exact copy of Channel 1's program, but 180° out of phase. When the speakers are connected between Channel 1+/2+ on the output terminal, twice the normal output voltage is now available across the load, *quadrupling* the apparent output power of the unit. This is best utilized when several transformer coupled, low wattage tapped speakers are needed to broadcast a program across a wide area, with up to a 500W maximum recommended transformer load. Only the "Channel 1 Output Level" control located on the back panel is used to adjust the final output level for both channels simultaneously.

9. Internal Trimming and Adjustments

Although most of the controls you'll need to setup your system are accessible via the back panel, there are a few gain adjustment trimmers located *inside* the chassis that can be adjusted in the field. Do not remove the lid or attempt to adjust the units internal trimmers unless the power to the unit is completely removed first, by physically disconnecting the AC inlet cable from the back panel or wall outlet. Any trimmer sealed with colored paint should never be adjusted and if done so will automatically void the units warranty. There are 3 user adjustable and 2 non-adjustable square, blue colored trimmers provided on the rear Processor PCB. Use a small flathead screwdriver to adjust the trimmers. Note that they only have a movement range of about 280° total. The controls available inside the MV-1.11X are Inputs #1 and #2 Gain, Microphone Gain, and Channel 1 and 2 Compressor Threshold Adjustment Trimmers.

10. Cooling Requirements

The MV-1.11X is designed to be convection cooled, but a fan attachment is sold separately if necessary. If your equipment is not getting installed into a rack make sure it is in a well cooled room and has plenty of room for air flow. Improper cooling can result in your amplifier being more likely to overheat. Refer to the Troubleshooting section for additional help.

11. Speaker Connections and Installation

THIS SECTION SHOULD ONLY BE CONSIDERED IF YOUR MV-1.11X AMPLIFIER IS BEING PURCHASED AND NOT PRE-INSTALLED BY A QUALIFIED TECHNICIAN. IF YOUR AMPLIFIER HAS ALREADY BEEN INSTALLED DO NOT MAKE ANY NON-USER ADJUSTMENTS.

The MV-1.11X Amplifier is 3.45" tall, by 8.50" wide and a maximum of 12.30" depth including hardware. Before you begin installation, make sure your amplifier is disconnected from the AC Mains power source, with its power switch in the "Off" position, and all level controls turned completely down.

To relocate your unit, turn the power switch off and remove the power plug from the AC outlet, then remove all connecting cables. Damaged cables may cause fire or electrical shock so discard accordingly. When setting up the product, make sure that the AC outlet you are using is easily accessible and can safely supply the unit(s) with the necessary current required.

When wiring your amplifier, make sure the mode switch is set on the appropriate setting you plan on wiring it for. Explanation of Operating Modes can be found on page 8. It is recommended to use a minimum of 18 AWG wire to connect the system to any speakers being driven.

DUAL MONO

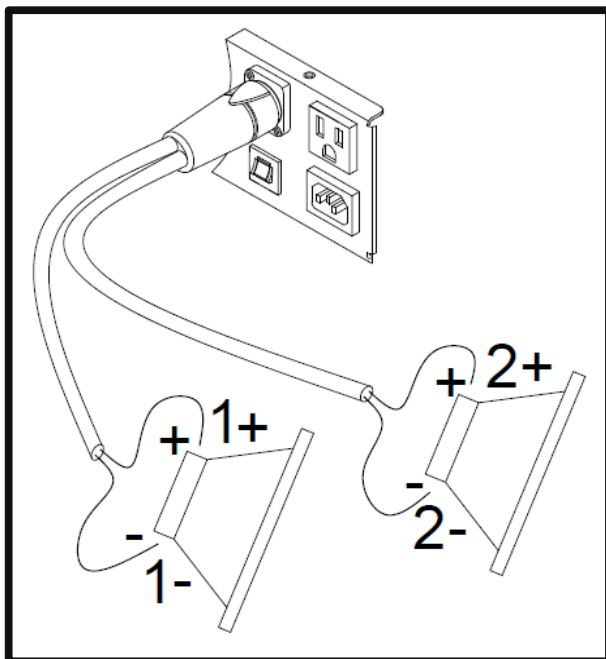

BRIDGED

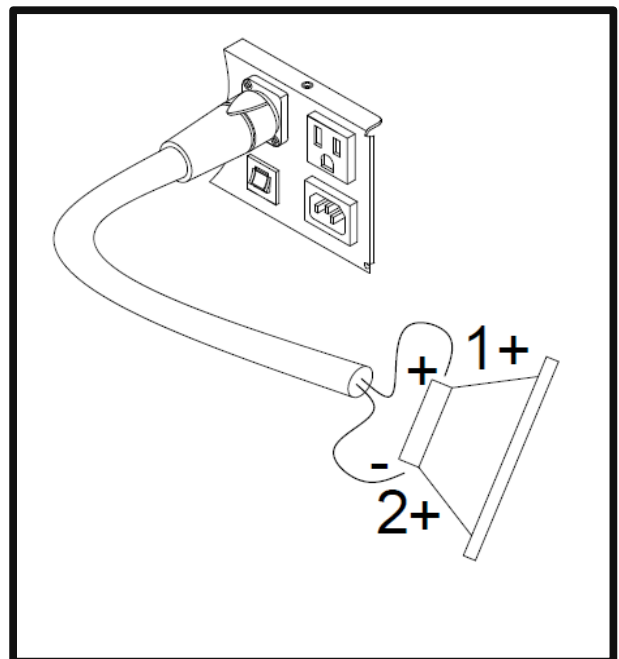

DUAL MONO MODE

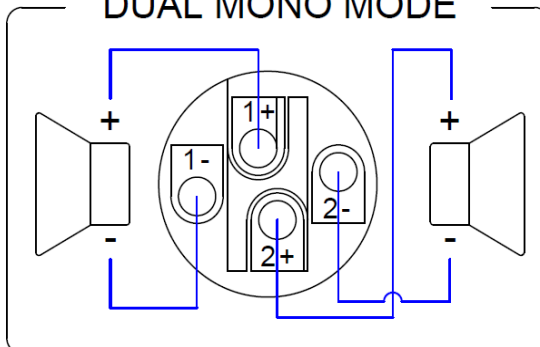

BRIDGED MODE

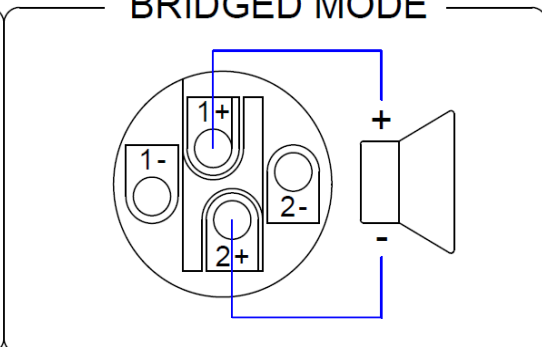

12. Troubleshooting



If your amplifier does not turn on, make sure the circuit breaker is not popped. If it is, please turn off your amplifier and reset the circuit breaker. If this is a repeating problem you may need to contact a qualified service professional. If the Power Switch LED [Green] stops illuminating, your amplifiers circuit breaker has most likely popped or there is a problem with AC mains supply main power line.

If the “PROTECT” Status LED comes on [Red], and your amplifier isn't producing any sound, It means your amplifier has either over heated, the speaker line is shorted, or a severe internal amplifier fault has occurred. If overheating as occurred, the amplifier will remain disconnected from the speaker until it has cooled down to an acceptable temperature, which at that point, it will automatically reset if no other faults are present and resume normal operation. If this is a repeating problem, contact LAR Audio Systems Support for assistance.

The Music and Microphone Active Indicators [Blue] will flash when a music or microphone signal is present at the amplifiers input jacks. If your system is not producing any sound, and your volume controls are turned up to an appreciable level, making sure that either of these LED's are flashing is a good starting point for troubleshooting.

13. Repairs and Servicing

All LAR Audio Systems Amplifiers are built to last and virtually indestructible. In the unlikely event that your amplifier breaks or malfunctions, please contact a qualified service technician before attempting to repair the equipment.

Equipment should be serviced by a qualified technician when:

- The power supply cord or the plug has been damaged.
- The equipment has been exposed to rain, or liquid had been spilled inside the amplifier.
- The equipment has been dropped or damaged in any other form.
- The equipment does not appear to be operating normally, or if you notice a change in performance.



If your power cord is damaged in any way, contact your dealer for a replacement. Using your amplifier with a damaged power cord is a fire hazard and you risk possible electrical shock. If your amplifier is dropped, or the equipment rack is damaged, turn the power switch off, remove the power plug from the AC outlet, and contact your dealer.



If you continue using your equipment without heeding this or any other instructions, fire or electrical shock may result. If you notice any abnormality, such as smoke, odor, or noise, or if a foreign object or liquid gets inside the unit, turn it off immediately. Remove the power cord from the AC outlet, and contact a qualified service professional.

14. Maintenance

- Your LAR Audio Amplifier requires no routine maintenance, but to extend the life of your amplifier it is best to keep it clean and dust free.
- There are no internal adjustments that need to be made during the amplifiers lifetime.
- There are no user serviceable parts inside the amplifier that require it to ever be opened.
- There are potentially *lethal* voltages inside the amplifier chassis, removing the cover increases risk of electric shock.
- Tampering with the circuitry or making unauthorized circuit changes, may be hazardous and potentially damage your equipment and voids your warranty.
- Refer all servicing to qualified service technicians authorized by LAR Audio Systems.

15. Amplifier Specifications

Music Preamplifier Stage Gain: Adjustable From 0dB to +9dB.

Microphone Preamplifier Stage Gain: Adjustable From Infinite Cut to +52dB.

Microphone Low Pass Filter: Hardware Defeatable (-18dB)/Octave Set to 120Hz.

Power Amplifier Stage Gain: [+28dB] Fixed

Front End Error Amp Topology: Long Tailed Pair, CCS Biased

Output Section Topology: Direct Coupled Class AB – Darlington BiPolar Output

Operating Voltage Rails: +/- 28VDC Unloaded, Earth Ground Referenced

Current Draw: 600mA Nominal, 1A Max

Input Impedance for Unbalanced Inputs 1 and 2: 17K Ω Per RCA Leg; +20dBu Max Input Level

Input Impedance for Low-Z Microphone Input: 1K Ω Per XLR Leg; -18dBu Max Input Level

Damping Factor: > 200 Into 8 Ω

Required AC Mains: 110-125VAC, 50-60Hz, 1A.

Number Of Output Channels: Two

DC Output Offset: No More Than +/- 100mVp Per Channel, Usually Less Than 15mVDC.

Quiescent Noise at Output: < 10mVp-p

Rise Time – Uncompensated – Non Filtered: 3 μ S. [10% to 90% at 5vp-p] – 10KHz. – No Load

Music Input Bandwidth: 4Hz. to 110KHz. – No Load

Amplifier Power Supply: Linear - 56 VA. – 6,800uF Shared Filter Capacitance Per Rail

Continuous Output Power Before Clipping – 1kHz. Sine Wave – Both Channels Driven:

- 8 Ohm Load: 16 W RMS Per Channel – Dual Mono Mode

- 4 Ohm Load: 18 W RMS Per Channel – Dual Mono Mode

- 8 Ohm Load: 40 W RMS Differential – Bridged Mono Mode

Minimum Load Impedance:

- 4 Ohms per channel: Dual Mono Mode

- 8 Ohms: Bridged Mono Mode

*** Integrator Note* :** If the amplifier is driving a 70V distributed speaker system in Bridged Mono Mode, the maximum transformer load should not exceed 500W.

Dimensions: 8.50" W x 3.45" H x 11.10" D

Weight: 5 lbs.

Chassis Material: 14 Gauge 5052-H32 Alodined Aluminum

All specifications subject to change without notice
Manual Revision 042723-V3

LAR Audio Systems
2733 Niagara Street
Niagara Falls, NY 14303
OFFICE. (716)-285-0555
EMAIL. larryk@laraudio.com
www.laraudio.com

